

TB 9-6625-2347-35

DEPARTMENT OF THE ARMY TECHNICAL BULLETIN

CALIBRATION PROCEDURE FOR OSCILLOSCOPE TEKTRONIX, MODEL 2213

Headquarters, Department of the Army, Washington, DC
30 September 2003

Distribution Statement A: Approved for public release; distribution is unlimited

REPORTING OF ERRORS AND RECOMMENDING IMPROVEMENTS

You can improve this manual. If you find any mistakes or if you know of a way to improve these procedures, please let us know. Mail your letter or DA Form 2028 (Recommended Changes to Publications and Blank Forms) directly to: Commander, U.S. Army Aviation and Missile Command, ATTN: AMSAM-MMC-MA-NP, Redstone Arsenal, AL 35898-5000. A reply will be furnished to you. You may also provide DA Form 2028 information to AMCOM via e-mail, fax, or the World Wide Web. Our fax number is DSN 788-6546 or Commercial 256-842-6546. Our e-mail address is: 2028@redstone.army.mil. Instructions for sending an electronic 2028 may be found at the back of this manual. For the World Wide Web, use <https://amcom2028.redstone.army.mil>.

SECTION		Paragraph	Page
I.	IDENTIFICATION AND DESCRIPTION		
	Test instrument identification	1	2
	Forms, records, and reports	2	2
II.	EQUIPMENT REQUIREMENTS		
	Calibration description	3	2
	Equipment required.....	4	3
III.	Accessories required	5	3
	CALIBRATION PROCESS		
	Preliminary instructions	6	4
	Equipment setup.....	7	4
	Vertical.....	8	5
	Horizontal.....	9	13
	Triggering.....	10	19
	Probe adjust.....	11	25
Power supply	12	25	
Final procedure	13	26	

SECTION I IDENTIFICATION AND DESCRIPTION

1. Test Instrument Identification. This bulletin provides instructions for the calibration of Oscilloscope Tektronix, Models 2213. The manufacturers' manuals were used as the prime data sources in compiling these instructions. The equipment being calibrated will be referred to as the TI (test instrument) throughout this bulletin.

a. Model Variations. Variations among models are listed in text.

b. Time and Technique. The time required for this calibration is approximately 3 hours, using the dc and low frequency technique.

2. Forms, Records, and Reports

a. Forms, records, and reports required for calibration personnel at all levels are prescribed by TB 750-25.

b. Adjustments to be reported are designated (R) at the end of the sentence in which they appear. When adjustments are in tables, the (R) follows the designated adjustment. Report only those adjustments made and designated with (R).

3. Calibration Description. TI parameters and performance specifications which pertain to this calibration are listed in table 1.

Table 1. Calibration Description

Test instrument parameters	Performance specifications
Vertical Deflection	Range: 2 mV/div to 10 V/div Accuracy: $\pm 3\%$
Bandwidth	Range: 2 mV/div to 10 mV/div Accuracy: Dc to at least 50 MHz Range: 20 mV/div to 10 V/div Accuracy: Dc to at least 60 MHz

Table 1. Calibration Description - Continued

Test instrument parameters	Performance specifications		
Horizontal			
A sweep timing	Range: 0.5 s/div to 0.05 μs/div Accuracy: ±3%		
	Range: (X10 mag): 50 ms/div to 5 ns/div Accuracy: ±5%		
Sweep linearity	Accuracy: ±3% (measured over any 2 of the center 8 divisions)		
Deflection (X-Axis)	Range: 2 mV/div to 10 V/div Accuracy: ±5%		
A trigger sensitivity	Frequency	≤ 2 MHz	2 MHz to 60 MHz
	Internal	0.4 div	1.5 div
	External	50 mV	250 mV
Probe adjust	Range: 0.5 V p-p Accuracy: ±20%		

SECTION II EQUIPMENT REQUIREMENTS

4. Equipment Required. Table 2 identifies the specific equipment to be used in this calibration procedure. This equipment is issued with Secondary Transfer Calibration Standards Set AN/GSM-286, AN/GSM-287, or AN/GSM-705. Alternate items may be used by the calibrating activity. The items selected must be verified to perform satisfactorily prior to use and must bear evidence of current calibration. The equipment must meet or exceed the minimum use specifications listed in table 2. The accuracies listed in table 2 provide a four-to-one ratio between the standard and TI. Where the four-to-one ratio cannot be met, the four-to-one accuracy of the equipment selected is shown in parenthesis.

5. Accessories Required. The accessories required for this calibration are common usage accessories issued as indicated in paragraph 4 above, and are not listed in this calibration procedure. The following peculiar accessory is also required for this calibration: standardizer, 5-80 pF.

Table 2. Minimum Specifications of Equipment Required

Common name	Minimum use specifications	Manufacturer and model (part number)
DIGITAL MULTIMETER	Range: -8.64 to < 0.1 V dc Accuracy: ±0.25%	John Fluke, Model 8840A/AF-05/09 (AN/GSM-64D)
OSCILLOSCOPE CALIBRATOR	Volts out: Range: 10 mV to 50 V Accuracy: ±0.75% Time markers: Range: 5 ns/D to 0.5 s/D Accuracy: ±0.75% Sine wave frequency: Range: 50 kHz to >100 MHz	John Fluke, Model 5820A, MIS-38938 (5820A-5C-GHZ)

SECTION III CALIBRATION PROCESS

6. Preliminary Instructions

a. The instructions outlined in paragraphs 6 and 7 are preparatory to the calibration process. Personnel should become familiar with the entire bulletin before beginning the calibration.

b. Items of equipment used in this procedure are referenced within the text by common name as listed in table 2.

c. Unless otherwise specified, verify the result of each test and, whenever the test requirement is not met, take corrective action before continuing with the calibration. Adjustments required to calibrate the TI are included in this procedure. Additional maintenance information is contained in the manufacturers' manuals for this TI.

d. When indications specified in paragraphs 8 through 11 are not within tolerance, perform the power supply check prior to making adjustments. After adjustments are made, repeat paragraphs 8 through 11. Do not perform power supply check if all other parameters are within tolerance.

e. Unless otherwise specified, all controls and control settings refer to TI.

7. Equipment Setup

WARNING

HIGH VOLTAGE is used or exposed during the performance of this calibration. DEATH ON CONTACT may result if personnel fail to observe safety precautions. REDUCE OUTPUT(S) to minimum after each step within the performance check where applicable.

a. Remove protective cover from TI only when necessary to make adjustments. Replace cover after completing the adjustments.

b. Connect TI to a 115 V ac source.

c. Position TI controls as listed in (1) through (15) below:

- (1) **AUTO INTENSITY** fully ccw.
- (2) **CH 1** and **CH 2** \updownarrow **POSITION** to midrange.
- (3) \Leftarrow **POSITION** \Rightarrow to midrange.
- (4) **VERTICAL MODE CH 1 BOTH CH 2** to **CH1**.
- (5) **CH1** and **CH2 VOLTS/DIV** variable fully cw to detent.
- (6) **CH2 INVERT** pushbutton to out position.
- (7) **CH1** and **CH2 AC GND DC** switches to **DC**.
- (8) **HORIZONTAL MODE** switch to **NO DLY**.

- (9) **SEC/DIV** switches to **.5 ms**.
 - (10) **SEC/DIV** variable fully cw to detent and pushed in.
 - (11) **VAR HOLDOFF** fully ccw to **NORM**.
 - (12) **TRIGGER MODE AUTO NORM TV FIELD** switch to **AUTO**.
 - (13) **SLOPE** switch to .
 - (14) **INT** switch to **VERT MODE**.
 - (15) **SOURCE** switch to **INT**.
- d. Press **TI POWER** pushbutton to **ON** and allow at least 20 minutes for warm-up.
 - e. Adjust **AUTO INTENSITY** and **AUTO FOCUS** controls for suitable viewing.

8. Vertical

a. Performance Check

- (1) Connect oscilloscope calibrator **SOURCE/MEASURE CHAN 1** to **TI CH 1 OR X** input and oscilloscope calibrator **SOURCE/MEASURE CHAN 2** to **TI CH 2 OR Y** input.
- (2) Set **TI CH 1 VOLTS/DIV** switch to **2m**.
- (3) Set oscilloscope calibrator **CH 1** for a **VOLTAGE** output of 10 mV at 1 kHz.
- (4) Adjust **TI TRIGGER LEVEL** and **POSITION** controls, as necessary, to view waveform.
- (5) Rotate oscilloscope calibrator knob located below **EDIT FIELD** key for 5 divisions of vertical display. If oscilloscope calibrator **Err** display does not indicate within limits specified in first row of table 3, perform **b** below.
- (6) Repeat technique of (2) through (5) above for settings listed in table 3. If oscilloscope calibrator **err** display does not indicate within limits specified in table 3, perform **b** below.

Table 3. CH 1 Vertical Deflection

Test instrument		Oscilloscope calibrator	
VOLTS/DIV setting	Divisions of vertical deflection	VOLTAGE output	Err display Indication (%)
2 m	5	10 mV	± 3
5 m	4	20 mV	± 3
10 m	5	50 mV	± 3
20 m	5	.1 V	± 3
50 m	4	.2 V	± 3
.1 V	5	.5 V	± 3
.2 V	5	1 V	± 3
.5 V	4	2 V	± 3
1 V	5	5 V	± 3
2 V	5	10 V	± 3
5 V	4	20 V	± 3
10 V	5	50 V	± 3

TB 9-6625-2347-35

- (7) Set oscilloscope calibrator output to standby.
- (8) Set TI **VERTICAL MODE CH 1 BOTH CH 2** switch to **CH 2** and **CH 2 VOLTS/DIV** switch to **2m**.
- (9) Set oscilloscope calibrator **CH 2** for a **VOLTAGE** output of 10 mV at 1 kHz.
- (10) Adjust TI **TRIGGER LEVEL** and **POSITION** controls, as necessary, to view waveform.
- (11) Rotate oscilloscope calibrator knob located below **EDIT FIELD** key for 5 divisions of vertical display. If oscilloscope calibrator **Err** display does not indicate within limits specified in first row of table 4, perform **b** below.
- (12) Repeat technique of (8) through (11) above for settings listed in table 4. If oscilloscope calibrator **err** display does not indicate within limits specified in table 4, perform **b** below.

Table 4. CH 2 Vertical Deflection

Test instrument		Oscilloscope calibrator	
VOLTS/DIV setting	Divisions of vertical deflection	VOLTAGE output	Err display Indication (%)
2 m	5	10 mV	± 3
5 m	4	20 mV	± 3
10 m	5	50 mV	± 3
20 m	5	.1 V	± 3
50 m	4	.2 V	± 3
.1 V	5	.5 V	± 3
.2 V	5	1 V	± 3
.5 V	4	2 V	± 3
1 V	5	5 V	± 3
2 V	5	10 V	± 3
5 V	4	20 V	± 3
10 V	5	50 V	± 3

- (13) Set oscilloscope calibrator output to standby.
- (14) Connect oscilloscope calibrator **SOURCE/MEASURE CHAN 1** through a 50Ω feed through termination to TI **CH 1** input and oscilloscope calibrator **SOURCE/MEASURE CHAN 2** through a 50Ω feed through termination to TI **CH 2** input.
- (15) Position TI switches as listed in (a) through (c) below:
 - (a) **VERTICAL MODE CH 1 BOTH CH 2** to **CH 1**.
 - (b) **CH 1** and **CH 2 VOLTS/DIV** to **2m**.
 - (c) **SEC/DIV** to **20 μs**.
- (16) Set oscilloscope calibrator for a **CHAN 1, LEVEL SINE** mode output of 12 mV at a frequency of 50 kHz.
- (17) Rotate oscilloscope calibrator knob below **EDIT FIELD** pushbutton to adjust amplitude for 6 divisions of deflection on TI.

NOTE

To perform step below; press oscilloscope calibrator **EDIT FIELD** pushbutton as required to place underline under one of the frequency digits.

(18) Rotate oscilloscope calibrator knob below **EDIT FIELD** pushbutton to sweep oscilloscope calibrator from 50 kHz to frequency limit specified in first row of table 5 while observing displayed waveform amplitude on TI crt. Displayed waveform amplitude will be within limits specified in first row of table 5 throughout entire frequency range sweep.

(19) Repeat technique of (15) (b) and (16) through (18) above for remaining TI settings and oscilloscope calibrator outputs in table 5. Displayed waveform amplitude will be within limits specified in table 5 throughout entire frequency range sweep.

Table 5. Channel 1 Bandwidth

Oscilloscope calibrator LEVEL SINE mode output		Test instrument		
Amplitude	Frequency sweep	VOLTS/DIV	SEC/DIV	Amplitude limits (divisions)
12 mV	50 kHz to 50 MHz ¹	2 m	20 μs	≥ 4.2
60 mV	50 kHz to 60 MHz ¹	10 m	20 μs	≥ 4.2
3.0 V	50 kHz to 60 MHz ¹	.5 V	20 μs	≥ 4.2

¹ Press **Set to 50 kHz** blue soft pushbutton to quickly return to 50 kHz.

(20) Set TI **VERTICAL MODE CH 1 BOTH CH 2** switch to **CH 2**.

(21) Ensure TI **CH 2 VOLTS/DIV** switch is set to **2m**.

(22) Set oscilloscope calibrator for a **CHAN 2, LEVEL SINE** mode output of 12 mV at a frequency of 50 kHz.

(23) Rotate oscilloscope calibrator knob below **EDIT FIELD** pushbutton to adjust amplitude for 6 divisions of deflection on TI.

NOTE

To perform step below; press oscilloscope calibrator **EDIT FIELD** pushbutton as required to place underline under one of the frequency digits.

(24) Rotate oscilloscope calibrator knob below **EDIT FIELD** pushbutton to sweep oscilloscope calibrator from 50 kHz to frequency limit specified in first row of table 6 while observing displayed waveform amplitude on TI crt. Displayed waveform amplitude will be within limits specified in first row of table 6 throughout entire frequency range sweep.

(25) Repeat technique of (21) through (24) above for remaining TI settings and oscilloscope calibrator outputs in table 6. Displayed waveform amplitude will be within limits specified in table 6 throughout entire frequency range sweep.

Table 6. Channel 2 Bandwidth

Oscilloscope calibrator LEVEL SINE mode output		Test instrument		
Amplitude	Frequency sweep	VOLTS/DIV	SEC/DIV	Amplitude limits (divisions)
12 mV	50 kHz to 50 MHz ¹	2 m	20 μs	≥ 4.2
60 mV	50 kHz to 60 MHz ¹	10 m	20 μs	≥ 4.2
3.0 V	50 kHz to 60 MHz ¹	.5 V	20 μs	≥ 4.2

¹ Press **Set** to **50 kHz** blue soft pushbutton to quickly return to 50 kHz.

- (26) Set oscilloscope calibrator to standby and disconnect equipment setup.
- (27) Connect oscilloscope calibrator **SOURCE/MEASURE CHAN 1** through a 50Ω feed through termination to a dual input coupler. Connect open ends of dual input coupler to **TI CH1 OR X** and **CH2 OR Y** inputs.
- (28) Set **TI CH 1** and **CH 2 VOLTS/DIV** switches to **20m**.
- (29) Set oscilloscope calibrator for a **CHAN 1, LEVEL SINE** mode output of 10 MHz and amplitude for 6 divisions of deflection on TI crt.
- (30) Adjust **CH 2 ⇕ POSITION** control to vertically center trace on center horizontal graticule line.
- (31) Set **TI VERTICAL MODE CH 1 BOTH CH 2** switch to **CH 1**.
- (32) Adjust **CH 1 ⇕ POSITION** control to vertically center trace on center horizontal graticule line.
- (33) Position TI controls as listed in (a) through (c) below:
 - (a) **VERTICAL MODE CH 1 BOTH CH 2** switch to **BOTH**.
 - (b) **VERTICAL MODE ADD ALT CHOP** switch to **ADD**.
 - (c) **INVERT** button pressed to **IN**.
- (34) Displayed trace amplitude will be 0.6 divisions or less.
- (35) Reduce output to minimum and disconnect equipment setup.

b. Adjustments

- (1) Disconnect equipment setup.
- (2) Position TI controls as listed in (a) through (o) below:
 - (a) **CH 1** and **CH 2 ⇕ POSITION** to midrange.
 - (b) **⇐ POSITION ⇒** to midrange.
 - (c) **VERTICAL MODE CH 1 BOTH CH 2** to **CH 1**.
 - (d) **CH 1** and **CH 2 VOLTS/DIV** switches to **20m**.
 - (e) **CH 1** and **CH 2 VOLTS/DIV CAL** fully cw to detent.
 - (f) **CH 2 INVERT** pushbutton to out position.
 - (g) **CH 1** and **CH 2 AC GND DC** switches to **DC**.
 - (h) **HORIZONTAL MODE** switch to **NO DLY**.
 - (i) **SEC/DIV** switch to **.5 ms**.
 - (j) **SEC/DIV** variable fully cw to detent and pushed in.

- (k) **VAR HOLDOFF** fully ccw to **NORM**.
 - (l) **TRIGGER MODE AUTO NORM TV FIELD** switch to **AUTO**.
 - (m) **SLOPE** switch to .
 - (n) **INT** switch to **VERT MODE**.
 - (o) **SOURCE** switch to **INT**.
- (3) Connect oscilloscope calibrator **SOURCE/MEASURE CHAN 1** to **TI CH 1 OR X** input.
- (4) Set oscilloscope calibrator for a **CH 1 VOLTAGE** output of 100 mV at 1 kHz.
- (5) Adjust R186 (fig. 1) for exactly 5 divisions of TI vertical deflection (R).

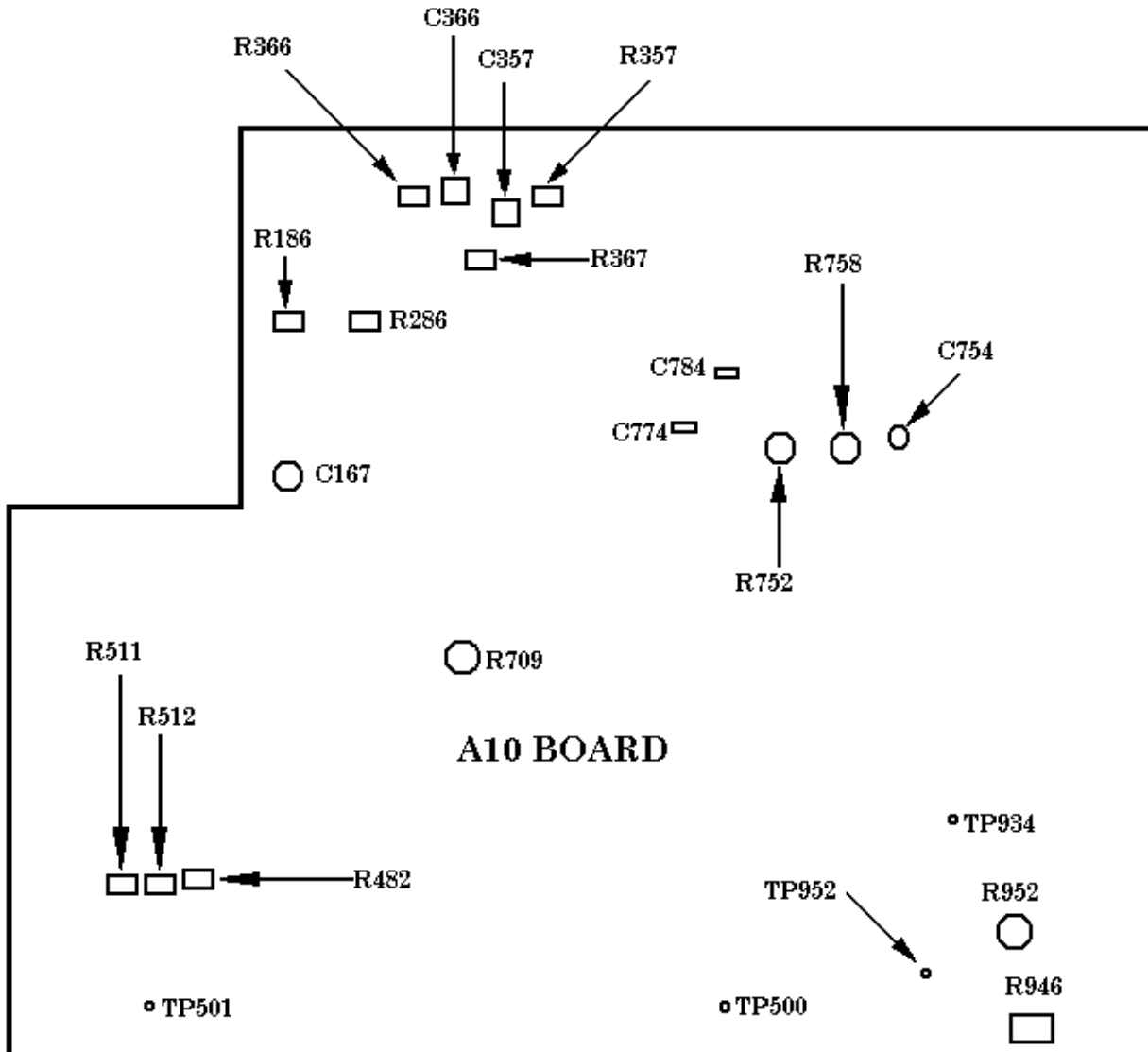

Figure 1. Adjustment locations A10 board.

- (6) Change oscilloscope calibrator output amplitude to 10 mV.

TB 9-6625-2347-35

- (7) Set TI CH 1 VOLTS/DIV switch to **2m**.
- (8) Adjust R145 (fig. 2) for exactly 5 divisions of TI vertical deflection (R).

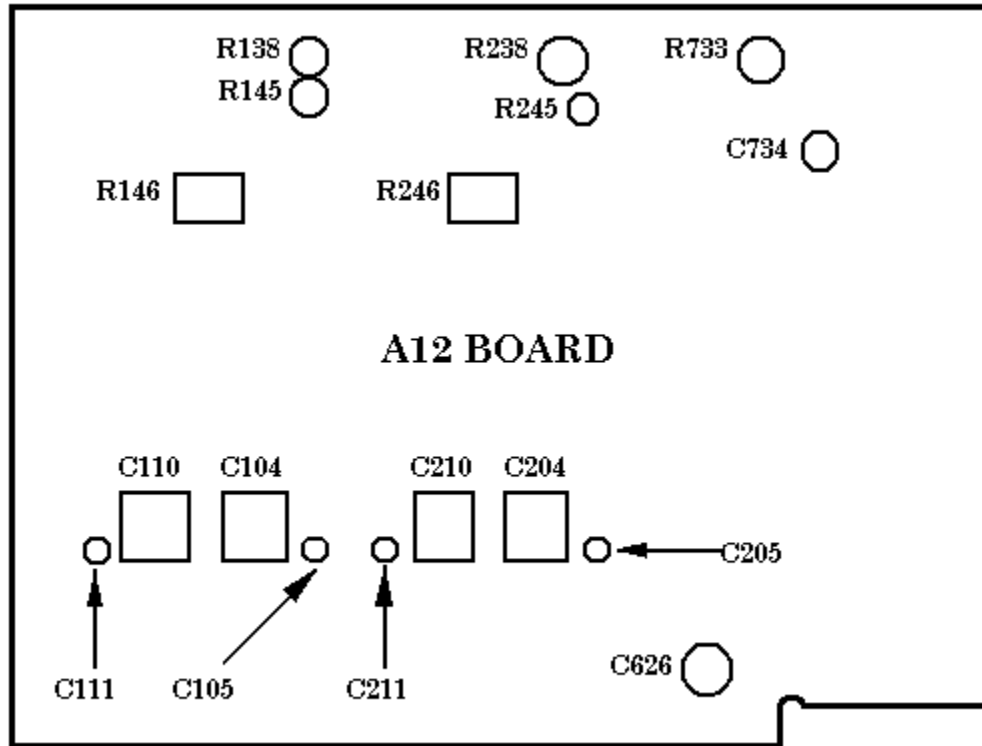

Figure 2. Adjustment location A12 board.

- (9) Set oscilloscope calibrator to **STANDBY**.
- (10) Set TI CH 1 AC GND DC switch to **GND**.
- (11) Set TI CH 1 VOLTS/DIV switch to **10m**.
- (12) Adjust CH 1 \updownarrow POSITION control to position trace on center horizontal graticule line.
- (13) Set TI CH 1 VOLTS/DIV switch to **2m**.
- (14) Adjust R138 (fig.2) to position trace on center horizontal graticule line.
- (15) Repeat (11) through (14) above for minimum trace shift when setting CH 1 VOLTS/DIV from **10m** to **2m**.
- (16) Set TI CH 1 VOLTS/DIV switch to **20m**.
- (17) Adjust CH 1 \updownarrow POSITION control to position trace on center horizontal graticule line.
- (18) Set TI CH 1 VOLTS/DIV switch to **10m**.
- (19) Adjust R146 (fig. 2) to position trace on center horizontal graticule line.

(20) Repeat (16) through (19) above for minimum trace shift when setting **CH 1 VOLTS/DIV** from **10m** to **20m**.

(21) Position TI switches as listed in (a) through (c) below:

- (a) **CH 1 VOLTS/DIV** to **20m**.
- (b) **CH 1 AC GND DC** to **DC**.
- (c) **SEC/DIV** to **.2 ms**.

(22) Disconnect oscilloscope calibrator **SOURCE/MEASURE CHAN 1** from **TI CH 1 OR X** input.

(23) Connect oscilloscope calibrator **SOURCE/MEASURE CHAN 1** to **TI CH 1 OR X** input using a 50Ω feedthrough termination.

(24) Set oscilloscope calibrator for a **CH 1, EDGE** mode output of 1 kHz and adjust amplitude for 5 divisions of TI vertical deflection.

(25) Adjust C105 (fig. 2) for best front corner and C104 (fig.2) for best flat top.

(26) Set **TI CH 1 VOLTS/DIV** switch to **2**.

(27) Adjust oscilloscope calibrator output for 5 divisions of TI vertical deflection.

(28) Adjust C111 (fig. 2) for best front corner and C110 (fig.2) for best flat top.

(29) Set oscilloscope calibrator to **STANDBY**.

(30) Move oscilloscope calibrator **SOURCE/MEASURE CHAN 1** connection from **TI CH 1 OR X** input to **TI CH 2 OR Y** input.

(31) Set **TI VERTICAL MODE CH 1 BOTH CH 2** switch to **CH 2**.

(32) Set oscilloscope calibrator for a **CH 1 VOLTAGE** output of 100 mV at 1 kHz.

(33) Adjust R286 (fig. 1) for exactly 5 divisions of TI vertical deflection (R).

(34) Change oscilloscope calibrator output amplitude to 10 mV.

(35) Set **TI CH 2 VOLTS/DIV** switch to **2m**.

(36) Adjust R245 (fig. 2) for exactly 5 divisions of TI vertical deflection (R).

(37) Set oscilloscope calibrator to **STANDBY**.

(38) Set **TI CH 2 AC GND DC** switch to **GND**.

(39) Set **TI CH 1 VOLTS/DIV** switch to **10m**.

(40) Adjust **CH 2 ↓POSITION** control to position trace on center horizontal graticule line.

(41) Set **TI CH 2 VOLTS/DIV** switch to **2m**.

(42) Adjust R238 (fig.2) to position trace on center horizontal graticule line.

(43) Repeat (39) through (42) above for minimum trace shift when setting **CH 2 VOLTS/DIV** from **10m** to **2m**.

(44) Set **TI CH 2 VOLTS/DIV** switch to **20m**.

(45) Adjust **CH 2 ↑POSITION** control to position trace on center horizontal graticule line.

TB 9-6625-2347-35

- (46) Set TI **CH 2 VOLTS/DIV** switch to **10m**.
- (47) Adjust R246 (fig.2) to position trace on center horizontal graticule line.
- (48) Repeat (44) through (47) above for minimum trace shift when setting **CH 2 VOLTS/DIV** from **10m** to **20m**.
- (49) Position TI switches as listed in (a) through (c) below:
 - (a) **CH 2 VOLTS/DIV** to **20m**.
 - (b) **CH 2 AC GND DC** to **DC**.
 - (c) **SEC/DIV** to **.2 ms**.
- (50) Disconnect oscilloscope calibrator **SOURCE/MEASURE CHAN 1** from TI **CH 2 OR Y** input.
- (51) Connect oscilloscope calibrator **SOURCE/MEASURE CHAN 1** to TI **CH 2 OR Y** input using a 50Ω feedthrough termination.
- (52) Set oscilloscope calibrator for a **CH 1, EDGE** mode output of 1 kHz and adjust amplitude for 5 divisions of TI vertical deflection.
- (53) Adjust C205 (fig. 2) for best front corner and C204 (fig. 2) for best flat top.
- (54) Set TI **CH 2 VOLTS/DIV** switch to **2**.
- (55) Adjust oscilloscope calibrator output for 5 divisions of TI vertical deflection.
- (56) Adjust C211 (fig. 2) for best front corner and C210 (fig. 2) for best flat top.
- (57) Set oscilloscope calibrator to **STANDBY** and disconnect setup.
- (58) Position TI controls as listed in (a) through (c) below:
 - (a) **CH 1 VOLTS/DIV** switch to **20m**.
 - (b) **CH 2 VOLTS/DIV** switch to **20m**.
 - (c) **SEC/DIV** switch to **.05 μs**.
- (59) Connect oscilloscope calibrator **SOURCE/MEASURE CHAN 1** to TI **CH 2 OR Y** input using a 10X attenuator and a 50Ω feedthrough termination.
- (60) Set oscilloscope calibrator for a **CH 1, EDGE** mode output of 1 MHz and adjust amplitude for 5 divisions of TI vertical deflection.
- (61) Preset R357 (fig. 1) to fully ccw position.
- (62) Adjust C357 (fig. 1) until ringing just disappears on front corner of displayed waveform.
- (63) Adjust R367 (fig. 1), R366 (fig. 1) and C366 (fig. 1) for best flat top beyond 20 ns from corner of displayed waveform.
- (64) Adjust R357 (fig. 1) and C357 (fig. 1) for best corner on first 20 ns of displayed waveform.
- (65) Repeat (63) and (64) above until no further improvement is noted.
- (66) Set TI **CH 2 VOLTS/DIV** switch to **.1** and (63) and (64) above for best compromise with **CH 2 VOLTS/DIV 20m** setting.
- (67) Set oscilloscope calibrator to **STANDBY**.
- (68) Position TI switches as listed in (a) through (c) below:

- (a) **CH 1 VOLTS/DIV** to **20 m**.
- (b) **CH 2 VOLTS/DIV** to **20 m**.
- (c) **SEC/DIV** to **20 μ s**.
- (69) Remove 10X attenuator from equipment connection.
- (70) Set oscilloscope calibrator for a **CH 1, LEVEL SINE** mode output of 50 kHz and adjust amplitude for 6 divisions of TI vertical deflection.
- (71) Rotate oscilloscope calibrator knob below **EDIT FIELD** pushbutton to increase oscilloscope calibrator frequency until the display decreases to 4.2 divisions of deflection.
- (72) Set oscilloscope calibrator to **STANDBY**.
- (73) Move connection from TI **CH 2 OR Y** input to TI **CH1 OR X** input.
- (74) Set TI **VERTICAL MODE CH 1 BOTH CH 2** switch to **CH 1**.
- (75) Set oscilloscope calibrator to **OPERATE**.
- (76) Adjust C167 (fig. 1) for 4.2 divisions of TI vertical deflection.
- (77) Reduce outputs to minimum and disconnect equipment setup.

9. Horizontal

a. Performance Check

- (1) Position TI controls as listed in (a) through (j) below:
 - (a) **VERTICAL MODE CH 1 BOTH CH 2** switch to **CH 1**.
 - (b) **CH 1 VOLTS/DIV** switch to **.5**.
 - (c) **INVERT** button depressed to out.
 - (d) **SEC/DIV** to **.05 μ s**.
 - (e) **TRIGGER MODE AUTO NORM TV FIELD** switch to **NORM**.
 - (f) **DELAY TIME** switch to **0.5 μ s**.
 - (g) **MULTIPLIER** knob fully ccw to **<X1**.
 - (h) **TRIGGER LEVEL** to midrange.
 - (i) **TRIGGER SOURCE** switch to **EXT**.
 - (j) **EXT COUPLING** switch to **DC÷10**.
- (2) Connect oscilloscope calibrator **SOURCE/MEASURE CHAN 1** to TI **CH 1 OR X** input and oscilloscope calibrator **EXT TRIG CH 5** to TI **EXT INPUT** using 50 Ω feedthrough terminations.
- (3) Set oscilloscope calibrator for a **CHAN 1, MARKER** mode output of 50 ns/div and **TRIGGER MODE** on and **TIMEDIV** to **/10**.
- (4) Adjust TI **TRIGGER LEVEL**, **INTENSITY**, and **CH 1 \updownarrow POSITION** controls for suitable viewing.
- (5) Adjust TI **\Leftarrow POSITION \Rightarrow** control to align 2nd time marker with 2nd vertical graticule line.
- (6) Rotate oscilloscope calibrator knob located below **EDIT FIELD** pushbutton to align 10th time marker with 10th vertical graticule line. If oscilloscope calibrator **err** display and TI linearity are not within limits specified in first row of table 7, perform **b** below.

TB 9-6625-2347-35

(7) Repeat technique of (3) through (6) above for remaining TI settings and oscilloscope calibrator outputs listed in table 7. If oscilloscope calibrator **err** display and TI linearity are not within limits specified in table 7, perform **b** below.

Table 7. A Sweep Timing

Oscilloscope calibrator		Test instrument	
MARKER output	Err display limit (%)	SEC/DIV setting	Linearity over any 2 of center 8 divisions (div)
50 nS/D	± 3	.05 µs	≤ 0.24
.1 µS/D	± 3	.1 µs	≤ 0.24
.2 µS/D	± 3	.2 µs	≤ 0.24
.5 µS/D	± 3	.5 µs	≤ 0.24
1 µS/D	± 3	1 µs	≤ 0.24
2 µS/D	± 3	2 µs	≤ 0.24
5 µS/D	± 3	5 µs	≤ 0.24
10 µS/D	± 3	10 µs	≤ 0.24
20 µS/D	± 3	20 µs	≤ 0.24
50 µS/D	± 3	50 µs	≤ 0.24
.1 mS/D	± 3	.1 ms	≤ 0.24
.2 mS/D	± 3	.2 ms	≤ 0.24
.5 mS/D	± 3	.5 ms	≤ 0.24
1 mS/D	± 3	1 ms	≤ 0.24
2 mS/D	± 3	2 ms	≤ 0.24
5 mS/D	± 3	5 ms	≤ 0.24
10 mS/D	± 3	10 ms	≤ 0.24
20 mS/D	± 3	20 ms	≤ 0.24
50 mS/D	± 3	50 ms	≤ 0.24
.1 S/D	± 3	.1 sec	≤ 0.24
.2 S/D	± 3	.2 sec	≤ 0.24
.5 S/D	± 3	.5 sec	≤ 0.24

(8) Pull TI **SEC/DIV** variable knob out for X10 sweep magnification.

(9) Set oscilloscope calibrator for a **CHAN 1, MARKER** mode output of 10 ns/div.

(10) Set TI **SEC/DIV** to **.05 µs**.

(11) Adjust TI **TRIGGER LEVEL, INTENSITY,** and **CH 1 ↕ POSITION** controls for suitable viewing.

(12) Adjust TI **⇐ POSITION ⇒** control to align 1st time marker that is 50 ns beyond start of sweep with 2nd vertical graticule line.

(13) Rotate oscilloscope calibrator knob located below **EDIT FIELD** pushbutton to align 5th time marker with 10th vertical graticule line. If oscilloscope calibrator **err** display and TI linearity are not within limits specified in table 8, perform **b** below.

Table 8. Sweep Timing (X10 out)

Oscilloscope calibrator		Test instrument	
MARKER output	Err display limit (%)	SEC/DIV setting	Linearity over any 2 of center 8 divisions (div)
10 nS/D	± 5	.05 µs	≤ 0.4

- (14) Set TI **SEC/DIV** to **.1 μs**.
- (15) Ensure oscilloscope calibrator is set for a **CHAN 1, MARKER** mode output of 10 ns/div.
- (16) Adjust TI **TRIGGER LEVEL, INTENSITY,** and **CH 1 ↓POSITION** controls for suitable viewing.
- (17) Adjust TI **←POSITION⇒** control to align 1st time marker that is 50 ns beyond start of sweep with 2nd vertical graticule line.
- (18) Rotate oscilloscope calibrator knob located below **EDIT FIELD** pushbutton to align 10th time marker with 10th vertical graticule line. If oscilloscope calibrator **err** display and TI linearity are not within limits specified in first row table 9, perform **b** below.
- (19) Repeat technique of (14) through (18) above for remaining TI settings and oscilloscope calibrator outputs listed in table 9. If oscilloscope calibrator **err** display and TI linearity are not within limits specified in table 9, perform **b** below.

Table 9. Sweep X10 Timing

Oscilloscope calibrator		Test instrument	
MARKER output	Err display limit (%)	SEC/DIV setting	Linearity over any 2 of center 8 divisions (div)
10 nS/D	± 5	.1 μs	≤ 0.4
20 nS/D	± 5	.2 μs	≤ 0.4
50 nS/D	± 5	.5 μs	≤ 0.4
.1 μS/D	± 5	1 μs	≤ 0.4
.2 μS/D	± 5	2 μs	≤ 0.4
.5 μS/D	± 5	5 μs	≤ 0.4
1 μS/D	± 5	10 μs	≤ 0.4
2 μS/D	± 5	20 μs	≤ 0.4
5 μS/D	± 5	50 μs	≤ 0.4
10 μS/D	± 5	.1 ms	≤ 0.4
20 μS/D	± 5	.2 ms	≤ 0.4
50 μS/D	± 5	.5 ms	≤ 0.4
.1 mS/D	± 5	1 ms	≤ 0.4
.2 mS/D	± 5	2 ms	≤ 0.4
.5 mS/D	± 5	5 ms	≤ 0.4
1 mS/D	± 5	10 ms	≤ 0.4
2 mS/D	± 5	20 ms	≤ 0.4
5 mS/D	± 5	50 ms	≤ 0.4
10 mS/D	± 5	.1 sec	≤ 0.4
20 mS/D	± 5	.2 sec	≤ 0.4
50 mS/D	± 5	.5 sec	≤ 0.4

- (20) Position TI controls as listed in (a) through (d) below:
 - (a) **CH 1 VOLTS/DIV** switch to **.5**.
 - (b) **SEC/DIV** variable knob pushed in.
 - (c) **SEC/DIV** to **.2 ms**.
 - (d) **SEC/DIV** variable knob to fully ccw.

TB 9-6625-2347-35

(21) Set oscilloscope calibrator is for a **CHAN 1, MARKER** mode output of 0.5 ms/div.

(22) Adjust **TRIGGER LEVEL, INTENSITY,** and **CH 1 ↕ POSITION** controls for suitable viewing.

(23) Adjust **TI ⇐ POSITION ⇒** control to align 2nd time marker with 2nd vertical graticule line.

(24) Displayed markers will be ≤ 1 division apart.

(25) Rotate **TI SEC/DIV** variable knob to fully cw detent position.

(26) Set oscilloscope calibrator output to minimum and disconnect equipment setup.

(27) Position **TI** controls as listed in (a) through (g) below:

(a) **CH1 AC GND DC** switch to **GND**.

(b) **HORIZONTAL MODE NO DLY INTENS DLY'D** switch to **INTENS**.

(c) **DELAY TIME MULTIPLIER** knob fully ccw to **< X1**.

(d) **DELAY TIME .02 ms 10 μs 0.5 μs** switch to **0.5 μs**.

(e) **SEC/DIV** to **.1 μs**.

(f) **TRIGGER SOURCE** switch to **INT**.

(g) **TRIGGER MODE** switch to **AUTO**.

(28) Nonintensified portion of **TI** displayed trace will be within limits specified in first row of table 10.

(29) Repeat technique of (27) (d) and (27) (e) above for remaining **TI** settings listed in table 10. Nonintensified portion of **TI** displayed trace will be within limits specified in table 10.

Table 10. Delay Time <X1

Test instrument		
DELAY TIME setting	SEC/DIV setting	Nonintensified limit (divisions)
0.5 μs	.1 μs	< 5
10 μs	2 μs	< 5
0.2 ms	50 μs	< 4

(30) Position **TI** controls as listed in (a) through (c) below:

(a) **DELAY TIME MULTIPLIER** knob fully cw to **> X20**.

(b) **DELAY TIME .02 ms 10 μs 0.5 μs** switch to **0.5 μs**.

(c) **SEC/DIV** to **2 μs**.

(31) Nonintensified portion of **TI** displayed trace will be within limits specified in first row of table 11.

(32) Repeat technique of (30) (b) and (30) (c) above for remaining **TI** settings listed in table 11. Nonintensified portion of **TI** displayed trace will be within limits specified in table 11.

Table 11. Delay Time >X20

Test instrument		
DELAY TIME setting	SEC/DIV setting	Nonintensified limit (divisions)
0.5 μ s	2 μ s	< 5
10 μ s	50 μ s	< 5
0.2 ms	1 ms	< 4

(33) Position TI controls as listed in (a) through (d) below:

- (a) **CH1 AC GND DC** switch to **DC**.
- (b) **CH 1 VOLTS/DIV** switch to **20m**.
- (c) **SEC/DIV** to **X-Y**.
- (d) **HORIZONTAL MODE NO DLY INTENS DLY'D** switch to **NO DLY**.

(34) Connect oscilloscope calibrator **SOURCE/MEASURE CHAN 1** to **TI CH 1 OR X** input.

(35) Set oscilloscope calibrator for a **CHAN 1, VOLT** mode output of 100 mV at 1 kHz.

(36) Rotate oscilloscope calibrator knob located below **EDIT FIELD** pushbutton until displayed trace is exactly 5 divisions in length. If oscilloscope calibrator **err** display is not within $\pm 5.0\%$, perform **b** below.

(37) Set oscilloscope calibrator output to minimum and insert a 50 Ω feedthrough termination into equipment connection.

(38) Set oscilloscope calibrator for a **CHAN 1, LEVEL SINE** mode output of 50 kHz and adjust amplitude for exactly 6 divisions of horizontal display on TI crt.

(39) Rotate oscilloscope calibrator knob below **EDIT FIELD** pushbutton to increase oscilloscope calibrator frequency until TI crt horizontal display decreases to 4.2 divisions.

(40) Oscilloscope calibrator frequency indication will be ≥ 2 MHz.

(41) Set oscilloscope calibrator output to minimum and disconnect equipment setup.

b. Adjustments

(1) Disconnect equipment setup.

(2) Position TI controls as listed in (a) through (r) below:

- (a) **CH 1 \updownarrow POSITION** to midrange.
- (b) **VERTICAL MODE CH 1 BOTH CH 2** to **CH 1**.
- (c) **CH 1** and **CH 2 VOLTS/DIV** switches to **.5**.
- (d) **CH 1** and **CH 2 VOLTS/DIV CAL** fully cw to detent.
- (e) **CH 2 INVERT** pushbutton to out position.
- (f) **CH 1 AC GND DC** switches to **DC**.
- (g) **CH 2 AC GND DC** switches to **GND**.
- (h) **\Leftarrow POSITION \Rightarrow** to midrange.
- (i) **HORIZONTAL MODE** switch to **NO DLY**.
- (j) **SEC/DIV** switch to **.1 ms**.
- (k) **SEC/DIV** variable fully cw to detent and pushed in.
- (l) **MULTIPLIER** knob fully ccw to **<X1**.

TB 9-6625-2347-35

- (m) **VAR HOLDOFF** fully ccw to **NORM**.
 - (n) **TRIGGER MODE AUTO NORM TV FIELD** switch to **AUTO**.
 - (o) **SLOPE** switch to .
 - (p) **INT** switch to **VERT MODE**.
 - (q) **SOURCE** switch to **EXT**.
 - (r) **EXT COUPLING** switch to **DC÷10**.
- (3) Connect oscilloscope calibrator **SOURCE/MEASURE CHAN 1** to **TI CH 1 OR X** input and oscilloscope calibrator **EXT TRIG CH 5** to **TI EXT INPUT** using 50 Ω feedthrough terminations.
- (4) Set oscilloscope calibrator for a **CHAN 1, MARKER** mode output of .1 ms/div and **TRIGGER MODE** on.
- (5) Adjust R752 (fig. 1) for 1 time marker per division over center eight divisions (R).
- (6) Pull TI **SEC/DIV** variable control to out position.
- (7) Change oscilloscope calibrator **CHAN 1, MARKER** mode output to 10 μ s/div.
- (8) Adjust R733 (fig. 2) for 1 time marker per division over center eight divisions (R).
- (9) Push TI **SEC/DIV** variable control to in position.
- (10) Change oscilloscope calibrator **CHAN 1, MARKER** mode output to 0.5 ms/div.
- (11) Adjust TI **⇐POSITION⇒** control to align middle time marker to center vertical graticule line.
- (12) Pull TI **SEC/DIV** variable control to out position.
- (13) Adjust R758 (fig. 1) to position middle time marker to center vertical graticule line.
- (14) Push TI **SEC/DIV** variable control to in position and check that there is no horizontal shift in time marker position.
- (15) Repeat (11) through (14) above until no further improvement is noted.
- (16) Set TI **SEC/DIV** switches to **5 μ s** and push **SEC/DIV** variable control to in position.
- (17) Change oscilloscope calibrator **CHAN 1, MARKER** mode output to 5 μ s/div.
- (18) Adjust C626 (fig. 2) for 1 time marker per division across graticule area (R).
- (19) Set TI **SEC/DIV** switches to **.05 μ s**.
- (20) Change oscilloscope calibrator **CHAN 1, MARKER** mode output to 50 ns/div.
- (21) Adjust C754 (fig. 1) for equally spaced time markers at start of sweep (R).
- (22) Pull TI **SEC/DIV** variable control to out position.
- (23) Change oscilloscope calibrator **CHAN 1, MARKER** mode output to 10 ns/Div.

NOTE





In the following adjustment, keep the adjustment screws for C774 (fig. 1) and C784 (fig. 1) as close to the same length as possible.

- (24) Adjust C774 (fig. 1) and C784 (fig. 1) alternately for one time marker per two divisions over center 8 divisions of magnified sweep (R).
- (25) Adjust \Leftarrow POSITION \Rightarrow control to align 5th time marker with 2nd vertical graticule line.
- (26) Adjust C734 (fig. 2) for 1 time marker per two divisions over center 8 divisions of magnified sweep (R).
- (27) Adjust \Leftarrow POSITION \Rightarrow control to check linearity of 15th time marker.
- (28) Repeat (24) through (27) above until no further improvement is noted.
- (29) Push TI SEC/DIV variable control to in position and adjust \Leftarrow POSITION \Rightarrow control to recenter trace.
- (30) Repeat (20) through (29) above until no further improvement is noted.
- (31) Position TI switches as listed in (a) through (c) below:
 - (a) CH 1 VOLTS/DIV to 20 m.
 - (b) SEC/DIV to X-Y.
 - (c) TRIGGER SOURCE to INT.
- (32) Set oscilloscope calibrator for a CHAN 1, VOLT DC mode output of 100 mV.
- (33) Adjust R709 (fig. 1) for exactly 5 divisions of horizontal deflection (R).

10. Triggering**a. Performance Check**





- (1) Position TI switches as listed in (a) through (d) below:
 - (a) CH 1 VOLTS/DIV to 2 m.
 - (b) CH 2 VOLTS/DIV to 20 m.
 - (c) SEC/DIV to .2 μ s.
 - (d) TRIGGER MODE AUTO NORM TV FIELD to AUTO.
- (2) Connect oscilloscope calibrator SOURCE/MEASURE CHAN 1 to TI CH 1 OR X input using a 50 Ω feedthrough termination.
- (3) Set oscilloscope calibrator for a CHAN 1, LEVEL SINE output of 2 MHz and 4 divisions of vertical display on TI.
- (4) Set TI CH 1 VOLTS/DIV switch to 20 m.
- (5) Set TI TRIGGER switches to combination listed in first row of table 12.
- (6) Adjust TI TRIGGER LEVEL control to obtain a stable display. If a stable display cannot be obtained perform **b** below.
- (7) Repeat technique of (5) and (6) above for remaining TRIGGER pushbutton combinations listed in table 12. If a stable display cannot be obtained perform **b** below.

Table 12. Trigger Level Channel 1

Test instrument			
TRIGGER switch combinations		TRIGGER LEVEL stable display	
MODE	SLOPE	YES	NO
AUTO			
AUTO			
NORM			
NORM			





- (8) Set TI **VERTICAL MODE CH1 BOTH CH2** switch to **CH 2**.
- (9) Set oscilloscope calibrator to **STANDBY** and move connection to TI **CH 2 OR Y** input.
- (10) Set oscilloscope calibrator to **OPERATE**.
- (11) Set TI **TRIGGER** switches to combination listed in first row of table 13.
- (12) Adjust TI **TRIGGER LEVEL** control to obtain a stable display. If a stable display cannot be obtained perform **b** below.
- (13) Repeat technique of (11) and (12) above for remaining **TRIGGER** pushbutton combinations listed in table 13. If a stable display cannot be obtained perform **b** below.

Table 13. Trigger Level Channel 2

Test instrument			
TRIGGER switch combinations		TRIGGER LEVEL stable display	
MODE	SLOPE	YES	NO
NORM			
NORM			
AUTO			
AUTO			





- (14) Set TI **SEC/DIV** switch to **.05 μs**.
- (15) Set oscilloscope calibrator for a **CHAN 1, LEVEL SINE** output of 60 MHz and 1.5 divisions of vertical display on TI.
- (16) Set TI **TRIGGER** switches to combination listed in first row of table 14.
- (17) Adjust TI **TRIGGER LEVEL** control to obtain a stable display. If a stable display cannot be obtained perform **b** below.
- (18) Repeat technique of (16) and (17) above for remaining **TRIGGER** pushbutton combinations listed in table 14. If a stable display cannot be obtained perform **b** below.

Table 14. Trigger Level Channel 2

Test instrument			
TRIGGER switch combinations		TRIGGER LEVEL stable display	
MODE	SLOPE	YES	NO
AUTO			
AUTO			
NORM			
NORM			

- (19) Set TI **VERTICAL MODE CH1 BOTH CH2** switch to **CH 1**.
- (20) Set oscilloscope calibrator to **STANDBY** and move connection to TI **CH 1 OR X** input.
- (21) Set oscilloscope calibrator to **OPERATE**.
- (22) Set TI **TRIGGER** switches to combination listed in first row of table 15.
- (23) Adjust TI **TRIGGER LEVEL** control to obtain a stable display. If a stable display cannot be obtained perform **b** below.
- (24) Repeat technique of (22) and (23) above for remaining **TRIGGER** pushbutton combinations listed in table 15. If a stable display cannot be obtained perform **b** below.

Table 15. Trigger Level Channel 1





Test instrument			
TRIGGER switch combinations		TRIGGER LEVEL stable display	
MODE	SLOPE	YES	NO
NORM			
NORM			
AUTO			
AUTO			

- (25) Reduce oscilloscope calibrator output to minimum and disconnect equipment setup.
- (26) Position TI switches as listed in (a) through (d) below:
 - (a) Ensure **VERTICAL MODE CH1 BOTH CH2** is set to **CH 1**.
 - (b) **CH 1 VOLTS/DIV** to **10 m**.
 - (c) **CH 2 VOLTS/DIV** to **10 m**.
 - (d) **SEC/DIV** to **20 μs**.
- (27) Connect oscilloscope calibrator **SOURCE/MEASURE CHAN 1** to dual input cable.
- (28) Connect one open end of dual input cable using 10X attenuator and 50 Ω feedthrough termination to TI **CH 1 OR X** input.
- (29) Connect other end of dual input cable using 10X probe supplied with TI to TI **CH 2 OR Y** input.

TB 9-6625-2347-35





- (30) Set oscilloscope calibrator for a **CHAN 1, LEVEL SINE** output of 50 kHz and 5 divisions of vertical display on TI.
- (31) Position TI controls as listed in (a) through (c) below:
 - (a) **VERTICAL MODE CH1 BOTH CH2** switch to **CH 2**.
 - (b) **SEC/DIV** switches to **.2 μs**.
 - (c) **TRIGGER SOURCE** switch to **EXT**.
- (32) Move connection from TI **CH 1 OR X** input to TI **EXT INPUT**.
- (33) Rotate oscilloscope calibrator knob below **EDIT FIELD** pushbutton to increase oscilloscope calibrator frequency to 2 MHz.
- (34) Set TI **TRIGGER** switches to combination listed in first row of table 16.
- (35) Adjust TI **TRIGGER LEVEL** control to obtain a stable display.
- (36) Repeat technique of (34) and (35) above for remaining **TRIGGER** pushbutton combinations listed in table 16.

Table 16. Trigger Level Ext Input 2 MHz

Test instrument			
TRIGGER switch combinations		TRIGGER LEVEL stable display	
MODE	SLOPE	YES	NO
AUTO			
AUTO			
NORM			
NORM			





- (37) Set oscilloscope calibrator to **STANDBY** and remove 10X attenuator from connection.
- (38) Set TI **TRIGGER EXT COUPLING AC DC DC÷10** switch to **DC÷10**.
- (39) Set oscilloscope calibrator to **OPERATE**.
- (40) Set TI **TRIGGER** switches to combination listed in first row of table 17.
- (41) Adjust TI **TRIGGER LEVEL** control to obtain a stable display.
- (42) Repeat technique of (40) and (41) above for remaining **TRIGGER** pushbutton combinations listed in table 17.

Table 17. Trigger Level Ext Input 2 MHz

Test instrument			
TRIGGER switch combinations		TRIGGER LEVEL stable display	
MODE	SLOPE	YES	NO
NORM			
NORM			
AUTO			
AUTO			





- (43) Position TI switches as listed in (a) through (e) below:
 - (a) **VERTICAL MODE CH1 BOTH CH2 to CH 1.**
 - (b) **CH 1 VOLTS/DIV to 10 m.**
 - (c) **CH 2 VOLTS/DIV to 10 m.**
 - (d) **SEC/DIV to 20 μ s.**
 - (e) **TRIGGER SOURCE** switch to **INT.**
- (44) Move connection from TI **EXT INPUT** input to TI **CH 1 OR X** and reinsert 10X attenuator.
- (45) Set oscilloscope calibrator for a **CHAN 1, LEVEL SINE** output of 50 kHz and 5 divisions of vertical display on TI.
- (46) Position TI controls as listed in (a) through (d) below:
 - (a) **VERTICAL MODE CH1 BOTH CH2** switch to **CH 2.**
 - (b) **SEC/DIV** switches to **.05 μ s.**
 - (c) Pull TI **SEC/DIV** variable knob out for X10 sweep magnification
 - (d) **TRIGGER SOURCE** switch to **EXT.**
- (47) Move connection from TI **CH 1 OR X** input to TI **EXT INPUT.**
- (48) Rotate oscilloscope calibrator knob below **EDIT FIELD** pushbutton to increase oscilloscope calibrator frequency to 60 MHz.
- (49) Set TI **TRIGGER** switches to combination listed in first row of table 18.
- (50) Adjust TI **TRIGGER LEVEL** control to obtain a stable display.
- (51) Repeat technique of (49) and (50) above for remaining **TRIGGER** pushbutton combinations listed in table 18.

Table 18. Trigger Level Ext Input 60 MHz

Test instrument			
TRIGGER switch combinations		TRIGGER LEVEL stable display	
MODE	SLOPE	YES	NO
AUTO			
AUTO			
NORM			
NORM			





- (52) Set oscilloscope calibrator to **STANDBY** and remove 10X attenuator from connection.
- (53) Set TI **TRIGGER EXT COUPLING AC DC DC÷10** switch to **DC÷10.**
- (54) Set oscilloscope calibrator to **OPERATE.**
- (55) Set TI **TRIGGER** switches to combination listed in first row of table 19.
- (56) Adjust TI **TRIGGER LEVEL** control to obtain a stable display.
- (57) Repeat technique of (55) and (56) above for remaining **TRIGGER** pushbutton combinations listed in table 19.

Table 19. Trigger Level Ext Input 60 MHz

Test instrument			
TRIGGER switch combinations		TRIGGER LEVEL stable display	
MODE	SLOPE	YES	NO
NORM			
NORM			
AUTO			
AUTO			

(58) Reduce oscilloscope calibrator output to minimum and disconnect equipment setup.

b. Adjustments

- (1) Disconnect equipment setup.
- (2) Position TI controls as listed in (a) through (p) below:
 - (a) **CH 1** \updownarrow **POSITION** to midrange.
 - (b) **VERTICAL MODE CH 1 BOTH CH 2** to **CH 1**.
 - (c) **CH 1** and **CH 2 VOLTS/DIV** switches to **20 m**.
 - (d) **CH 1** and **CH 2 VOLTS/DIV CAL** fully cw to detent.
 - (e) **CH 2 INVERT** pushbutton to out position.
 - (f) **CH 1** and **CH 2 AC GND DC** switches to **DC**.
 - (g) \Leftarrow **POSITION** \Rightarrow to midrange.
 - (h) **HORIZONTAL MODE** switch to **NO DLY**.
 - (i) **SEC/DIV** switch to **20 μ s**.
 - (j) **SEC/DIV** variable fully cw to detent and pushed in.
 - (k) **VAR HOLDOFF** fully ccw to **NORM**.
 - (l) **TRIGGER MODE AUTO NORM TV FIELD** switch to **AUTO**.
 - (m) **SLOPE** switch to .
 - (n) **INT** switch to **VERT MODE**.
 - (o) **SOURCE** switch to **INT**.
 - (p) **EXT COUPLING** switch to **DC**.
- (3) Connect oscilloscope calibrator **SOURCE/MEASURE CHAN 1** to TI **CH 1 OR X** input using a 50 Ω feedthrough termination.
- (4) Set oscilloscope calibrator for a **CHAN 1, LEVEL SINE** output of 50 kHz and 5 divisions of TI vertical display.
- (5) Adjust R482 (fig. 1) for a positive vertical shift of 0.15 division at sweep start when changing TI **TRIGGER SLOPE** switch between  and  positions (R).
- (6) Set TI **TRIGGER SLOPE** switch to  and TI **TRIGGER LEVEL** knob to fully cw position.
- (7) Adjust oscilloscope calibrator output amplitude for 1 division of TI vertical display.

- (8) Adjust R511 (fig. 1) so that display just triggers on positive peak of signal (R).
- (9) Set TI **TRIGGER SLOPE** switch to  and TI **TRIGGER LEVEL** knob to fully ccw position.
- (10) Adjust R512 (fig. 1) so that display just triggers on negative peak of signal (R).
- (11) Set TI **TRIGGER MODE** switch to **NORM**.
- (12) Ensure TI **TRIG'D** indicator is illuminated when a stable display is present and is not illuminated when a stable display is not present.
- (13) Reduce outputs to minimum and disconnect equipment setup.

11. Probe Adjust

a. Performance Check

- (1) Connect TI **PROBE ADJUST** to TI **CH 1 OR X** input.
- (2) Set TI **SEC/DIV** switch to **.5 ms**, **CH 1 VOLTS/DIV** switch to **.1** and variable control for 5 divisions of vertical display (do not change setting).
- (3) Disconnect TI **PROBE ADJUST** from TI **CH 1 OR X** input.
- (4) Connect oscilloscope calibrator **SOURCE/MEASURE CHAN 1** to TI **CH 1 OR X** input.
- (5) Set oscilloscope calibrator for a **CH 1 VOLTAGE** mode output of 500 mV at 1 kHz.
- (6) Adjust TI **TRIGGER LEVEL** and **POSITION** controls, as necessary, to view waveform.
- (7) Rotate oscilloscope calibrator knob located below **EDIT FIELD** key for 5 divisions of vertical display.
- (8) Oscilloscope calibrator **err** display will indicate within $\pm 20\%$.
- (9) Reduce outputs to minimum and disconnect equipment setup.
- (10) If necessary, rotate TI **CH 1 VOLTS/DIV CAL** fully cw to detent.

b. Adjustments None

12. Power Supply

NOTE

Do not perform power supply check if all other parameters are within tolerance.

a. Performance Check.

- (1) Connect digital multimeter low lead to TI TP934 (fig. 1) and multimeter hi lead to TI TP952 (fig. 1). If digital multimeter does not indicate between 4.2 and 4.4 V dc, perform **b** (1) below.
- (2) Remove digital multimeter leads.

TB 9-6625-2347-35

(3) Connect digital multimeter low lead to TI TP501 (fig. 1) and multimeter hi lead to TI TP500 (fig. 1). If digital multimeter does not indicate between -8.56 and -8.64 V dc, perform **b** (2) below.

b. Adjustments.

- (1) Adjust R952 (fig. 1) for a digital multimeter indication of 4.3 V dc (R).
- (2) Adjust R946 (fig. 1) for a digital multimeter indication of -8.60 V dc (R).

13. Final Procedure

- a.** Deenergize and disconnect all equipment.
- b.** Annotate and affix label/form in accordance with TB 750-25.

By Order of the Secretary of the Army:

Official:

PETER J. SCHOOMAKER
General, United States Army
Chief of Staff



JOEL B. HUDSON
Administrative Assistant to the
Secretary of the Army

0321104

Distribution:

To be distributed in accordance with IDN 344788 requirements for calibration procedure
TB 9-6625-2347-35.

INSTRUCTIONS FOR SUBMITTING AN ELECTRONIC 2028

The following format must be used if submitting an electronic 2028. The subject line must be exactly the same and all fields must be included; however, only the following fields are mandatory: 1, 3, 4, 5, 6, 7, 8, 9, 10, 13, 15, 16, 17, and 27.

From: "Whomever" whomever@redstone.army.mil

To: <2028@redstone.army.mil

Subject: DA Form 2028

1. **From:** Joe Smith
2. **Unit:** home
3. **Address:** 4300 Park
4. **City:** Hometown
5. **St:** MO
6. **Zip:** 77777
7. **Date Sent:** 19-OCT-93
8. **Pub no:** 55-2840-229-23
9. **Pub Title:** TM
10. **Publication Date:** 04-JUL-85
11. **Change Number:** 7
12. **Submitter Rank:** MSG
13. **Submitter FName:** Joe
14. **Submitter MName:** T
15. **Submitter LName:** Smith
16. **Submitter Phone:** 123-123-1234
17. **Problem:** 1
18. **Page:** 2
19. **Paragraph:** 3
20. **Line:** 4
21. **NSN:** 5
22. **Reference:** 6
23. **Figure:** 7
24. **Table:** 8
25. **Item:** 9
26. **Total:** 123
27. **Text**

This is the text for the problem below line 27.

PIN: 080970-000